

- Notes:
- 100% pass test
 - Data transmission
 - The external dimension of USB A male terminal is $12 \pm 0.2 \text{mm}$
 - The outer diameter of the USB C head is $6.65 \pm 0.1 \text{mm}$
 - This product meets the RoHS standard.
 - Wire Printing: 80°C 30V VISION

Pin assignment:

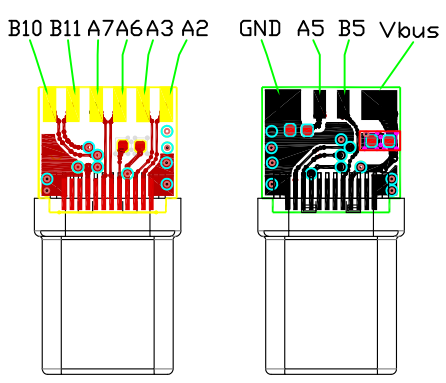
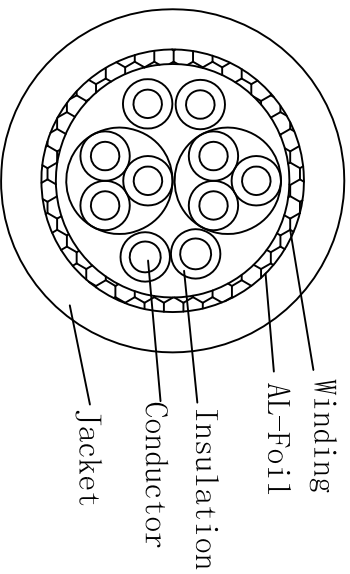
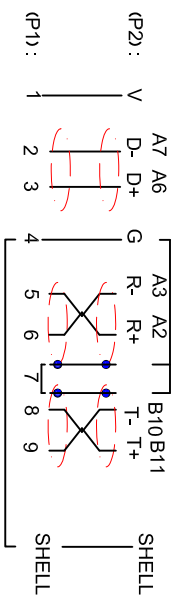

No	Material	Specifications	Unit	Dosage
1	USB 3.0	30AWG(7/0.10TC*0.5HDPE)*1P+30AW G(7/0.10TC*0.5HDPE*1P+D7/0.10TC *0.5PE+AL)*2P+39/0.10TC*1.0HDPE *1C+28/0.10TC*0.9PE*1C+AL+SP67/ 0.10TC OD:4.0 WHI PVC	M	2.02/3.02
2	TYPE-C 3.0	6-B112G EB6 CM Tensile pearl nickel 3.0 4 laminar plate RP = 56K C = 10nf	PCS	1
3	USB3.0 AM	iron clad nickel, blue glue	PCS	1
4	Internal model	LD PE	kg	0.003000
5	External mold	35P White pvc	kg	0.015
6	Wire	OD: 0.6MM Lead-free	kg	0.00003
7	Tie	White PVC 10cm	PCS	2

TOLERANCE	SIGNATURE		DATE
	$L \leq 1.5 \text{mm}$	$\pm 10 \text{mm}$	Drawing: neo
$1.5 \text{mm} < L \leq 5 \text{mm}$	$\pm 20 \text{mm}$	Checking:	
$5 \text{mm} < L \leq 10 \text{mm}$	$\pm 40 \text{mm}$	Approval:	
Unit: mm		DRAFT	USB.AT.029
		CUSTOMER No.:	
		VERSION	A0